

## SFP+ 10G (DUAL FIBER)



### **GOXP-1596-40**

40KM SFP+ ER Optical Transceiver

#### > Description:

**GOXP-1596-40**  
**SFP+, 10G, 1550NM,**  
**40KM, SMF, DDM**

## > Overview:

SFP+ER Transceiver is designed for 10GBASE-ER/EW, and 8.5G/10G Fiber- Channel applications. The transceiver consists of two sections: The transmitter section incorporates a cooled EML laser. And the receiver section consists of a PIN photodiode integrated with a TIA. All modules satisfy class I laser safety requirements. SFP+ER Digital diagnostics functions are available via a 2-wire serial interface, as specified in SFF-8472, which allows real-time access to device operating parameters such as transceiver temperature, laser bias current, transmitted optical power, received optical power and transceiver supply.

## > Features:

- Compliant with SFF-8431 and IEE802.3ae
- Compliant with SFF-8431 and IEE802.3ae
- Data rate selectable ≤4.25Gbps or 9.95Gbps to 10.3Gbps bit rates
- OUT2 10.70G Line rate support
- Cooled EML transmitter and PIN receiver link length up to 40km
- Low Power Dissipation 1.5W Maximum
- -5 to 70 degree Operating Temperature
- Single 3.3V power supply
- Diagnostic Performance Monitoring of module temperature, supply Voltages, laser bias current, transmit optical power, receive optical power
- RoHS compliant and lead free

## > Applications:

- 10GBASE-ER/EW (with/without FEC)
- 10G Fiber Channel (with/without FEC)
- SDH/SONET

## > Absolute Maximum Ratings:

Parameter	Symbol	Min	Max	Unit
Supply Voltage	Vcc	-0.5	3.8	V
Storage Temperature	Tst	-40	85	°C
Relative Humidity	Rh	0	85	%

## > Operating Conditions:

Parameter	Symbol	Min	Typical	Max	Unit
Supply Voltage	Vcc	3.13	3.3	3.47	V
Supply current	Icc		360	450	mA
Operating Case temperature	Tca	-5	-	70	°C
Module Power Dissipation	Pm	-	1.2	1.5	W

Notes:

[1] Supply current is shared between VCCTX and VCCR<sub>X</sub>.

[2] In-rush is defined as current level above steady state current requirements

## > Transmitter Specifications – Optical:

Parameter	Symbol	Min	Typical	Max	Unit
Center Wavelength	c	1530		1565	nm
Optical Average Power	Po	0	-	+3	dBm
Optical OMA Power	Pom	-2.1			dBm
Side Mode Suppression Ratio	SMSR	30	-	-	dB
Optical Transmit Power (disabled)	PTX_DISABLE	-	-	-30	dBm
Extinction Ratio	ER	8.2		-	dB
RIN <sub>21OMA</sub> [1]				-128	dB/Hz
Optical Return Loss Tolerance				21	dB

Notes:

[1] RIN measurement is made with a return loss at 21 dB

## > Transmitter Specifications - Electrical:

Parameter	Symbol	Min	Typical	Max	Unit
Data Rate	Mra	-	10.3	11.3	Gbps
Input differential impedance	Rim	-	100	-	Ω
Differential data Input	VtxDIFF	120	-	850	mV
Transmit Disable Voltage	VD	2.0	-	Vcc3+0.3	V
Transmit Enable Voltage	Ven	0	-	+0.8	V
Transmit Disable Assert Time	Vn	-	-	100	us

Notes:

[1] RIN measurement is made with a return loss at 21 dB

> Receiver Specifications - Optical:

Parameter	Symbol	Min	Typical	Max	Unit
Input Operating Wavelength	$\lambda$	1530	-	1565	nm
Average receive power		-	-	-1.0	dBm
Receiver sensitivity in OMA		-	-	-14.1	dBm
Stressed receiver sensitivity in OMA[1]				-11.3	dBm
Maximum Input Power	RX-overload	-	-	-1	dBm
Reflectance	Rrx	-	-	-27	dB
Loss of Signal Asserted		-25	-	-	dBm
LOS De-Asserted		-	-	-16	dBm
LOS Hysteresis		0.5	-	-	dB

Notes:

[1] Measured with conformance test signal for BER = 10<sup>-12</sup>. The stressed sensitivity values in the table are for system level BER measurements which include the effects of CDR circuits. It is recommended that at least 0.4 dB additional margin be allocated if component level measurements are made without the effects of CDR circuits.

> Receiver Specifications – Electrical:

Parameter	Symbol	Min	Typical	Max	Unit
Data Rate	Mra	-	10.3	11.3	Gbps
Differential Output Swing	Vout P-P	350	-	850	mV
Rise/Fall Time	Tr / Tf	24	-	-	ps
Loss of Signal –Asserted	VOH	2	-	Vcc3+0.3-	V
Loss of Signal –Negated	VOL	0	-	+0.4	V

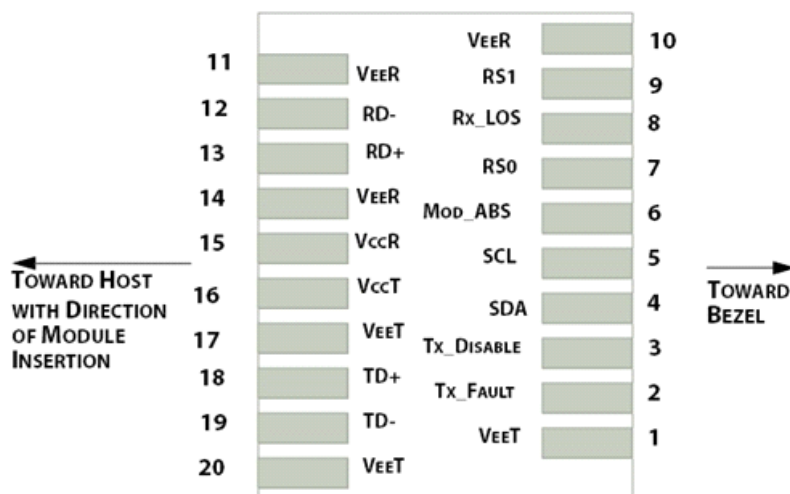

Figure1.Electrical Pin-out Details

> Pin Description:

Pin	Symbol	Name/Description
1	VEET [1]	Transmitter Ground
2	Tx_FAULT [2]	Transmitter Fault
3	Tx_DIS [3]	Transmitter Disable. Laser output disabled on high or open
4	SDA [2]	2-wire Serial Interface Data Line
5	SCL [2]	2-wire Serial Interface Clock Line
6	MOD_ABS [4]	Module Absent. Grounded within the module
7	RS0 [5]	RS0 for Rate Select: Open or Low = Module supports ≤4.25Gbps High = Module supports 9.95 Gb/s to 10.3125 Gb/s
8	RX_LOS [2]	Loss of Signal indication. Logic 0 indicates normal operation
9	RS1 [5]	No connection required
10	VEER [1]	Receiver Ground
11	VEER [1]	Receiver Ground
12	RD-	Receiver Inverted DATA out. AC Coupled
13	RD+	Receiver DATA out. AC Coupled
14	VEER [1]	Receiver Ground
15	VCCR	Receiver Power Supply
16	VCCT	Transmitter Power Supply
17	VEET [1]	Transmitter Ground
18	TD+	Transmitter DATA in. AC Coupled
19	TD-	Transmitter Inverted DATA in. AC Coupled
20	VEET [1]	Transmitter Ground

**Notes:**

1. Module circuit ground is isolated from module chassis ground within the module.
2. Should be pulled up with 4.7k – 10k ohms on host board to a voltage between 15V and 3.6V. 3Tx\_Disable is an input contact with a 4.7 kΩ to 10 kΩ pullup to VccT inside the module.
3. Mod\_ABS is connected to VeeT or VeeR in the SFP+ module. The host may pull this contact up to Vcc\_Host with a resistor in the range 4.7 kΩ to 10 kΩ. Mod\_ABS is asserted “High” when the SFP+ module is physically absent from a host slot.
4. RS0 and RS1 are module inputs and are pulled low to VeeT with > 30 kΩ resistors in the module

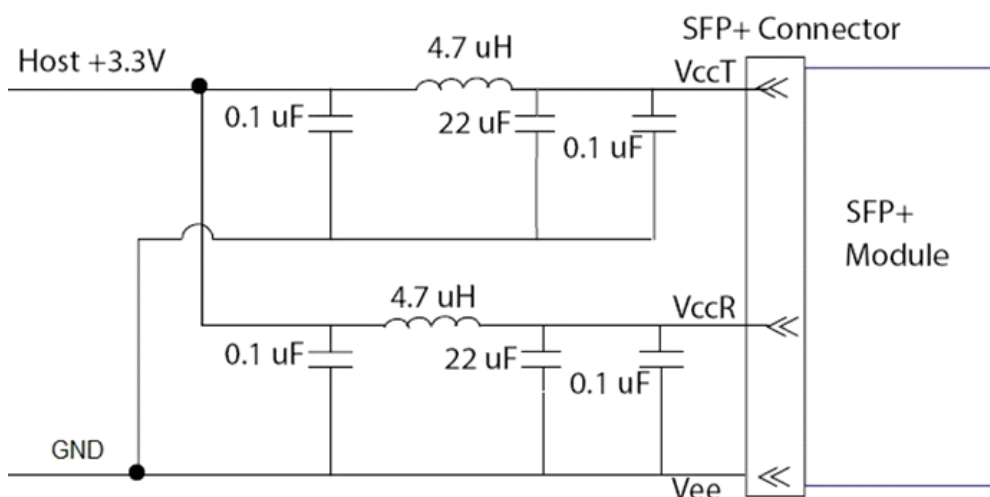

Figure2. Host Board Power Supply Filters Circuit

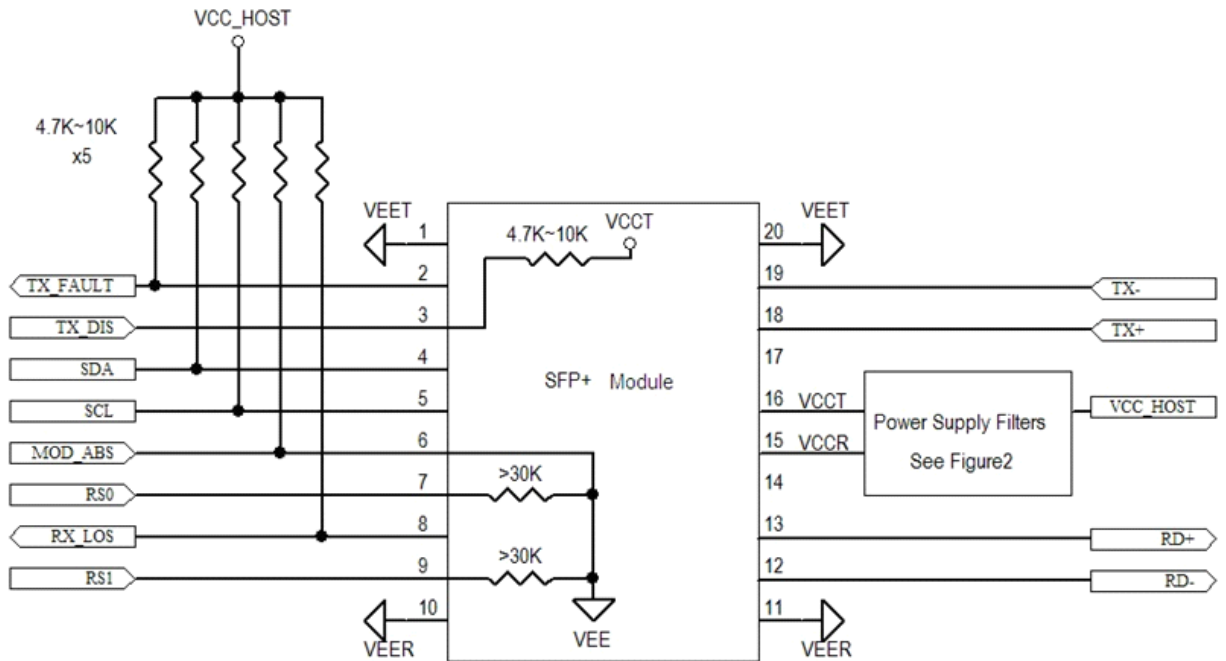

Figure3. Host-Module Interface

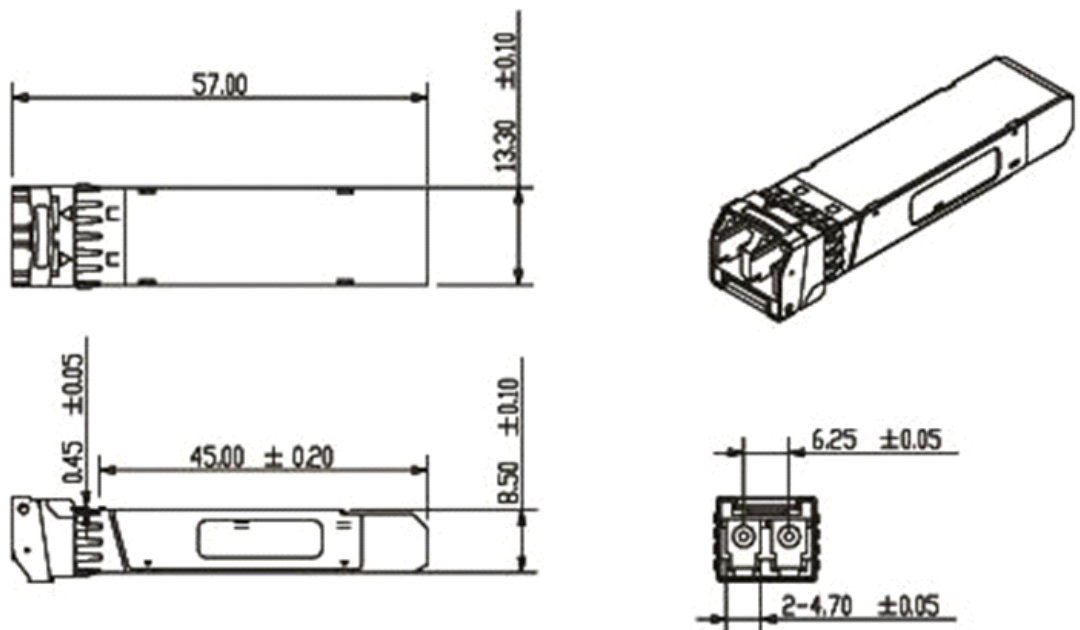

Figure4. Mechanical Specifications

➤ Ordering Information:

Part Number	Product Description
GOXP-1596-40	10Gbps, 1550nm SFP+ER 40km, -5 ~ +70 degree

