

CP-UNC-WE21L3C-MDS-Q

2MP Network IR Wedge Camera - 30Mtr.

- 1/2.8" 2MP PS CMOS Image Sensor (0.9071 centimeter)
- 1920(H) × 1080(V) @25/30 fps
- H.265, H.264, H.264H, H.264B, MJPEG
- Rotation mode, WDR(120dB), 3D DNR, HLC, BLC, AWB
- 2.8mm fixed lens (3.6mm optional)
- IR Range of 30 Mtr.
- Built-in Mic ,IP67, K10, Micro SD Card, PoE

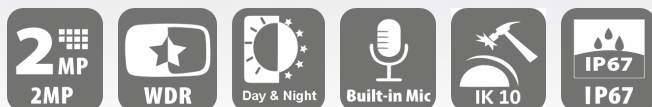

System Overview

This Camera is the perfect solution for various kinds of vehicles, including bus, coach, van etc. The vehicle mounted CCTV cameras enable drivers and operator to check anytime what happen inside and outside the vehicle by delivering a live feed on the monitor of everything in the camera view, including people or obstacles. Moreover, fitted with Infra-Red LEDs for improved night vision and combined with a robust, durable casing, the operation system offers unrivalled performance and clarity.

MTBF

Secure Boot : With an impressive Mean Time Between Failures (MTBF) of over 100,000 hours, this camera delivers exceptional durability with its ability to perform seamlessly in demanding environments. Constructed with industrial-grade components, it is engineered to withstand the rigors of continuous operation, making it a perfect fit for critical applications such as 24/7 surveillance and public safety monitoring.



CP-UNC-WE21L3C-MDS-Q

2MP Network IR Wedge Camera - 30Mtr.

CTC Technology:

CP PLUS Trusted Core Technology is a multi-layered security architecture that brings together the best of cyber security practices and technological intelligence. It is not just an enhancement; it is a complete redefinition of how surveillance should function in today's digital landscape - more intelligent, more secure, and more reliable than ever before.

Functions

Wide Dynamic Range (WDR)

When a scene is partly dark and partly bright, that is the dynamic range that distorts images due to this difference in the lighting. WDR technology provides you balanced lighting for a clear and vivid image throughout the day. WDR technology can be installed at entry/exit points of any building structure, jewellery shops, outdoor location among so many other places.

Starlight Technology

This camera is widely used to provide sharper and clearer picture quality with the help of its exceptional starlight sensitivity as the camera improves night vision in low light conditions. This technology is useful in conditions with extremely low light as the starlight technology turns almost completely dark images into those of clear colors.

True Day/Night (ICR)

When the scene is too dark, the image is captured by illuminating an infrared light through the camera onto the scene that greatly helps with making the scene visible for the lens. It delivers color images during the day and automatically switches to the monochrome feature as the scene darkens.

IK10 Technology

This product has been inculcated with the IK10 vandal resistance technology which is the topmost mechanical protection in the surveillance industry. This technology enables your camera in developing a strong and robust appearance that can't be defeated by water, dust or even severe shocks as the powerful housing of this camera deters any damage from occurring.

About CP PLUS

The brand that is on its way to lead the world when it comes to the security and surveillance industry, CP PLUS, keeps bombarding the market with the most reliable range of products that have been designed carefully and methodically to automate the whole surveillance and security process, no matter how big your premises are.

It was the initiative to help the public in the area where they are the most vulnerable and to empower the sense of safety in our hearts that had conceptualized CP PLUS. And embarking on its mission to make the world a safer and more secure place has taken the brand's journey to unprecedented levels even when compared to international competitors.



CP-UNC-WE21L3C-MDS-Q

2MP Network IR Wedge Camera - 30Mtr.

Feature	Specification
Image Sensor	1/2.8" 2MP PS CMOS Image Sensor (0.9071 centimeter)
Minimum Illumination	0.006 Lux@F1.6(Color,30IRE), 0.0006 Lux@F1.6(B/W,30IRE) 0 lux (IR on)
Effective Pixels	1920(H) × 1080(V)
Shutter Speed	Auto/Manual 1/3 s–1/100000 s
Angle Adjustment	Pan: -30°- 30°, Tilt: 0°- 80°, Rotation: 0°- 360°
White Balance	Auto/Manual
Lens	2.8mm fixed lens (3.6mm optional)
Gain Control(AGC)	Auto/Manual
Lens Type	Fixed
Iris Type	Fixed
Lens Mount	M12
Back Light Compensation	BLC/ HLC/ WDR(120 dB)
Angle of View	2.8mm: Horizontal: 107°, Vertical: 56.3°, Diagonal: 126.4°
S/N Ratio	> 56 dB
Video Format	PAL/NTSC
OSD	Camera title, Date & Time
Video Compression	Instream, H.265, H.264, H.264H, H.264B, MJPEG (only supported by the sub stream)
Bit Rate Control	CBR/VBR
Bit Rate	H.264: 3 kbps–6144 kbps, H.265: 3 kbps–6144 kbps
Noise Reduction	3D DNR
Privacy Mask	4 Areas
Audio Compression	PCM, G.711a, G.711Mu, G.726, MPEG2-Layer2, G.722.1
Frame Rate	Main stream: 2MP/1.3MP/1MP/D1@(1-25/30fps), Sub stream 1: D1/VGA/CIF@(1-25/30fps) Sub stream 2: 2MP/1.3MP/1MP/D1@(1-25/30fps), Sub stream 3: D1/VGA/CIF@(1-25/30fps)
Protocol	IPv4, IPv6, HTTPS, TCP/IP, HTTP, RTP, ARP, RTSP, SMTP, FTP, SFTP, DHCP, DNS, UPnP, NTP, Unicast, Multicast, NFS, PPPoE, SNMP, ICMP, ONVIF (Profile S, Profile G, Profile T)

Feature	Specification
IVS (Perimeter Protection)	Tripwire, Intrusion, Object Abandon/ Missing, IMD (Intelligent motion detection), Face Detection.
Day/Night	Auto (ICR)
Ethernet	1 (Built-in M12 port, and it supports the network data of 10 M/100 M)
Alarm Event	Motion/tampering detection, audio detection, network disconnection detection, IP conflict detection, memory card state detection, memory space detection
Cyber Security	AES 256-bit Encryption, Configuration encryption, trusted execution, Digest, security logs, WSSE, account lockout, syslog, video encryption, IP/MAC filtering, HTTPS, trusted upgrade, trusted boot.
User/Host	20 Users
Mirror Function	Support
Browser	Microsoft Edge and Chrome
Audio	Built in Mic
Operating Humidity	≤95% RH, Non condensing
Operating Temperature	−40°C to +70°C ,85°C (For 10 minutes)
IR Distance	IR Range of 30 Mtr.
IR Number	2(IR Light)
Defog	Support
Image Rotation	Support
Certificates	MTBF Certificate from STQC, IEC 61373, IEC 60571 and IEC 60068-2-10, IEC 50155, EN50121-4:2016, EN61000-4-3:2010, EN 50155, ISO9001, STQC approved compliance report
Storage	SFTP, NAS, Micro SD card (support max. 512 GB)
Power Source	PoE (802.3af)
Power Consumption	< 4.5 W (PoE)
Weatherproof Standard	IP67, IK10
Dimension	64.8mm × 111.0mm
Casing	Metal
Weight	0.45kg

Published Date –28-04-2025

Dimensions (mm/inch)

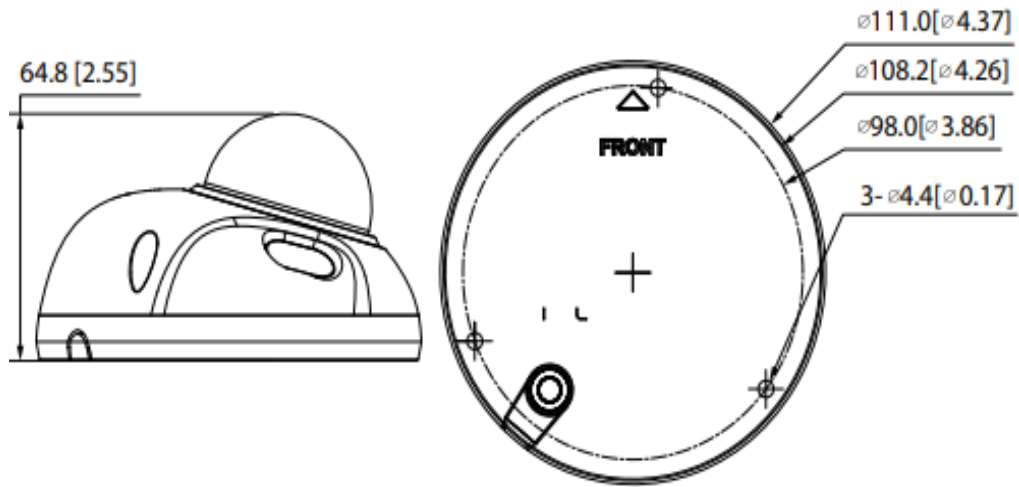

Company Name:

CP PLUS (Aditya Infotech Ltd.)

F-28 Okhla Industrial Area, Phase 1,

New Delhi 110020, INDIA

Contact Mail ID :- customercare@cpplusworld.com