

CP-UNC-TC61L5C-VMD-LQ

6MP Dual Light Bullet Camera - 50Mtr.

- 1/2.7" 6MP PS CMOS Image Sensor (0.9407 centimeters)
- Max. 6MP (3288 × 1850)@1–20 fps
- Instastream, H.265, H.264, H.264H, H.264B, MJPEG
- Support Quad Stream
- WDR(120dB), Day/Night(ICR), 3D NR, ROI, AWB, AGC, BLC, HLC, Digital watermarking
- IR Range of 50 Mtr., Warm Light Range of 30 Mtr.
- 3.6mm Lens
- Support Starlight Technology
- Micro SD Card, PoE, IP67, IK10 (optional)

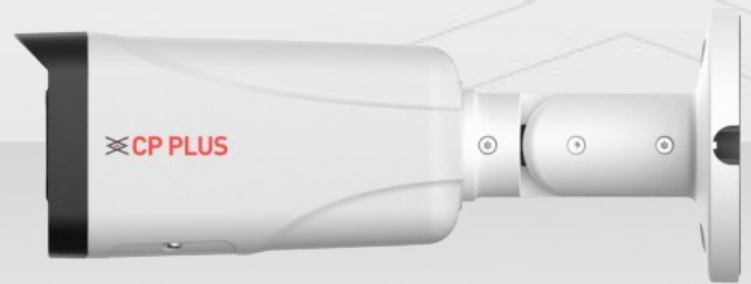

System Overview

The CP PLUS Advanced Dual Light Cameras provide the perfect solution for elevating your security system. Designed for superior adaptability, these cameras support multiple illumination modes and advanced monitoring features, ensuring unmatched performance in various environments.

CTC Technology:

CP PLUS Trusted Core Technology is a multi-layered security architecture that brings together the best of cyber security practices and technological intelligence. It is not just an enhancement; it is a complete redefinition of how surveillance should function in today's digital landscape - more intelligent, more secure, and more reliable than ever before.



CP-UNC-TC61L5C-VMD-LQ

6MP Dual Light Bullet Camera - 50Mtr.

Functions

Instastream

This camera has been designed with the latest and most efficient innovation among the standard video compression designs. Smart encoding algorithms developed by CP PLUS help in saving up to 70% more bandwidth than H.265 along with making it more beneficial for minimizing bandwidth and storage costs. It enhances video coding efficiency while providing high resolution and the rate of frame in the video using Intelligent Region Perception to detect motion in each frame.

Regions of interest

Regions of Interest (ROI) is a user defined feature that allows the operator to monitor specific areas of a scene while still maintaining overall situational awareness of less important areas.

True Day/Night

When the scene is too dark, the image is captured by illuminating an infrared light through the camera onto the scene that greatly helps with making the scene visible for the lens. It delivers color images during the day and automatically switches to the monochrome feature as the scene darkens.

Power over Ethernet

CP PLUS cameras with Power over Ethernet (PoE) technology offer a simple and efficient installation by using a single Ethernet cable to deliver both power and data. This eliminates the need for separate power adapters, reduces cable clutter, and ensures a cleaner setup.

About CP PLUS

The brand that is on its way to lead the world when it comes to the security and surveillance industry, CP PLUS, keeps bombarding the market with the most reliable range of products that have been designed carefully and methodically to automate the whole surveillance and security process, no matter how big your premises are.

It was the initiative to help the public in the area where they are the most vulnerable and to empower the sense of safety in our hearts that had conceptualized CP PLUS. And embarking on its mission to make the world a safer and more secure place has taken the brand's journey to unprecedented levels even when compared to international competitors.



CP-UNC-TC61L5C-VMD-LQ

6MP Dual Light Bullet Camera - 50Mtr.

Feature	Specification
Image Sensor	1/2.7" 6MP PS CMOS Image Sensor (0.9407 centimeters)
Effective Pixels	3288 (H) × 1850 (V)
Minimum Illumination	0.001 lux@F1.4 (Color, 30 IRE), 0.0001 lux@F1.4 (B/W, 30 IRE), 0 lux (IR on)
Angle Adjustment	Pan: 0°–360°, Tilt: 0°–90°, Rotation: 0°–360°
Shutter Speed	Auto/Manual 1/3 s–1/100,000 s
White Balance	Auto, Natural, Street lamp, Outdoor, Manual, Regional custom
RAM	256 MB
ROM	128 MB
DORI Distance	85.4 m (Detect), 34.2 m (Observe), 17.1 m (Recognize), 8.5 m (Identify)
Gain Control(AGC)	Auto/ Manual
Lens Type	Fixed-focal
Max. Aperture	F1.4
Close Focus Distance	1.7 m
Lens	3.6mm Lens
Lens Mount	M12
S/N Ratio	>58 dB
IR Number	2 IR LED, 2 Warm Light
IR	IR Range of 50 Mtr.
Warm Light	Warm Light Range of 30 Mtr.
Smart IR	Support
Back Light Compensation	BLC/ HLC/ WDR(120dB)
Angle of View	H: 91°, V: 46°, D: 110°
Video Compression	Instastream, H.265, H.264, H.264H, H.264B, MJPEG (Only supported by sub stream)
IR Control	Auto, Manual
Audio	Built-in Mic
OTA (Over-The-Air)	Support

Feature	Specification
Stream Capability	Quad Stream
Frame Rate	Main stream: 6MP (3288 × 1850)@1–20 fps/ 4MP (2688 × 1520)@1–25/30 fps, Sub Stream 1: D1@25fps Sub Stream 2: D1@25fps Sub Stream 3:D1@1fps
IVS (Perimeter Protection)	Intrusion, tripwire (the two functions support the classification and accurate detection of vehicle and human)
Video format	PAL/NTSC
Privacy Mask	4 areas
ROI	Support (4 areas)
Audio Input	1 Channel (RCA port)
Audio Output	1 Channel (RCA port)
OSD	Camera title, Date & Time
Audio Compression	G.711a, G.711Mu, G.726, PCM, AAC
Smart search	Work together with Smart NVR to perform refine intelligent search, event extraction and merging to event videos
Resolution	6MP (3288 × 1850), 5MP (2880 × 1620), 4MP (2688 × 1520), 3MP (2048 × 1536/ 2304 × 1296), 2MP (1920 × 1080), 1.3MP (1280 × 960), 720p (1280 × 720), D1 (704 × 576/704 × 480), VGA (640 × 480), CIF (352 × 288/352 × 240)
Noise Reduction	3D NR
Motion detection	OFF/ON (4 areas, rectangular)
Bit Rate	H.265: 3 kbps–8192 kbps, H.264: 3 kbps–8192 kbps
Bit Rate Control	CBR/ VBR
Protocol	SFTP, IPv6, IPv4, DNS,RTCP, NTP, RTP, HTTP, HTTPS, SNMP V3, TLS Version 1.2, TCP/IP, PPPoE, NFS, UDP, ICMP, SSL, DHCP, SMTP, RTSPS, InstaOn, ONVIF (Profile S, Profile G, Profile T), unicast, multicast
SDK and API	Support
Ethernet	RJ-45 (10/100 Base-T)
Day/Night	Auto(ICR)/Color/B/W
Alarm Event	No SD card, SD card full, SD card error, Network disconnection, IP conflict, illegal access, Motion detection, Video tampering, Tripwire, Intrusion, Audio detection, Voltage detection, IMD (Intelligent motion detection), Security exception, External alarm
Iris Control	Fixed
Mirror Function	Support

Feature	Specification
IMD (Intelligent motion detection)	Support
Cyber Security	AES 256-bit Encryption, Configuration encryption, trusted execution, Digest, security logs, WSSE, account lockout, syslog, video encryption, IP/MAC filtering, HTTPS, trusted upgrade, trusted boot
Image Rotation	0°/90°/180°/270° (Support 90°/270° with 2688 × 1520 resolution and lower)
User/Host	20 (Total bandwidth: 48 M)
Alarm IN	1 Channel in: 5 mA 3–5 VDC
Alarm Out	1 Channel out: 300 mA 12 VDC
Browser	IE: IE11, Chrome, Firefox
Storage	SFTP, NAS, Mirco SD card (Max. 512GB)
Certificates	ISO 9001: 2015, ISO 20000-1 : 2018, CE, FCC and RoHS, BIS, STQC approved compliance report
Power Source	12 VDC, PoE
Power Consumption	Basic: 2.2 W (12 VDC), 2.9 W (PoE); Max.: 6.4 W (12 VDC), 8 W (PoE) (H.265 + intelligence on+ WDR + illuminator intensity)
Weatherproof Standard	IP67, IK10 (optional)
Operating Temperature	–40 °C to +60 °C (–40 °F to +140 °F)
Operating Humidity	≤95% (RH), non-condensing
Storage Temperature	–40 °C to +60 °C (–40 °F to +140 °F)
Storage Humidity	≤95% (RH), non-condensing
Casing	Metal
Dimension	238.5 mm × 90.7 mm × 90.7 mm
Weight	720g

Published Date –15-12-2025

Dimensions (mm/inch)

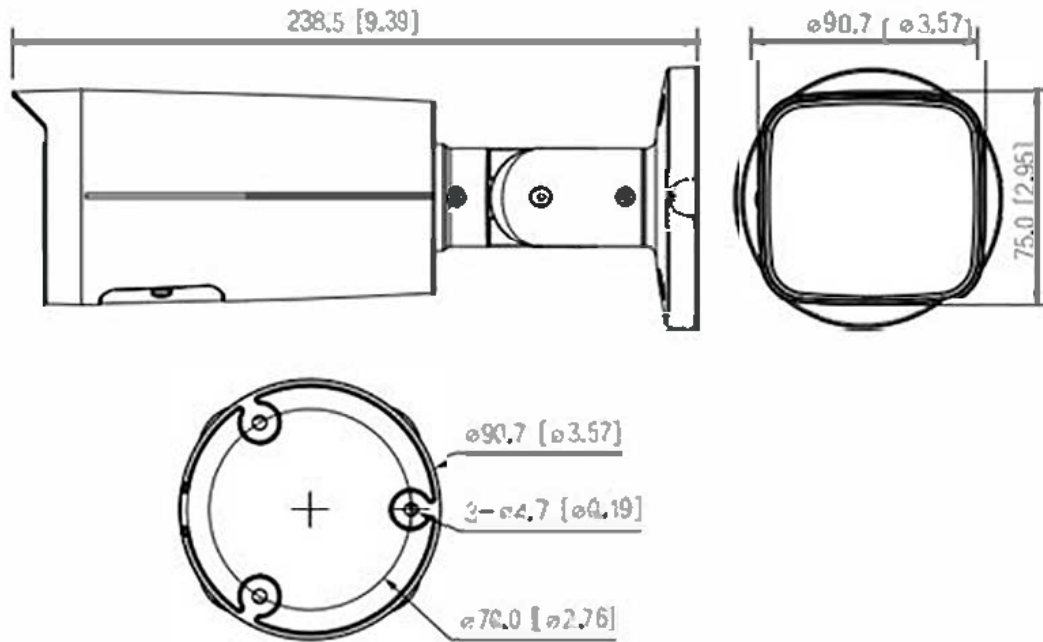

Company Name:

CP PLUS (Aditya Infotech Ltd.)

F-28 Okhla Industrial Area, Phase 1,

New Delhi 110020, INDIA

Contact Mail ID :- customercare@cpplusworld.com