

CP-UNC-VE21ZL4C-VMDS-Q

2MP Network IR Vandal Dome Camera - 40Mtr.

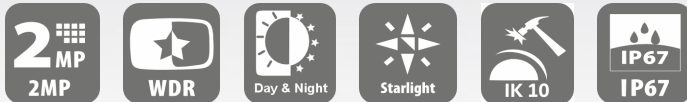

- 1/2.8" 2MP PS CMOS Image Sensor (0.9071 Centimeter)
- 1920(H) × 1080(V) @25/30 fps
- Instastream, H.265, H.264+, H.264, H.264H, H.264B, MJPEG
- Support Quad Stream
- WDR(120dB), Day/Night(ICR), 3D DNR, ROI, Defog, BLC, HLC, AWB, AGC
- 2.7mm ~13.5mm Motorized lens
- IR Range of 40 Mtr.
- Support Starlight Technology
- Built-in Mic, Digital watermarking, Micro SD, IP67, IK10, PoE



System Overview

This Series has gathered a lot of fame over the years for its eminent capabilities on top of its artful appearance which lets it mix in any background. This series entails a wide range of easily-mountable solutions that have been crafted with the IR Megapixel technology that delivers resolutions varying from 2MP to 8MP depending on your choice of products. This Series comes with a varifocal lens/motorized/fixed lens and is absolutely pocket-friendly, which makes it the best choice for a number of small and mid-size places

MTBF

Secure Boot : With an impressive Mean Time Between Failures (MTBF) of over 100,000 hours, this camera delivers exceptional durability with its ability to perform seamlessly in demanding environments. Constructed with industrial-grade components, it is engineered to withstand the rigors of continuous operation, making it a perfect fit for critical applications such as 24/7 surveillance and public safety monitoring.



CP-UNC-VE21ZL4C-VMDS-Q

2MP Network IR Vandal Dome Camera - 40Mtr.

CTC Technology:

CP PLUS Trusted Core Technology is a multi-layered security architecture that brings together the best of cyber security practices and technological intelligence. It is not just an enhancement; it is a complete redefinition of how surveillance should function in today's digital landscape - more intelligent, more secure, and more reliable than ever before.

Functions

Wide Dynamic Range (WDR)

When a scene is partly dark and partly bright, that is the dynamic range that distorts images due to this difference in the lighting. WDR technology provides you balanced lighting for a clear and vivid image throughout the day. WDR technology can be installed at entry/exit points of any building structure, jewellery shops, outdoor location among so many other places.

Starlight Technology

This camera is widely used to provide sharper and clearer picture quality with the help of its exceptional starlight sensitivity as the camera improves night vision in low light conditions. This technology is useful in conditions with extremely low light as the starlight technology turns almost completely dark images into those of clear colors.

True Day/Night (ICR)

When the scene is too dark, the image is captured by illuminating an infrared light through the camera onto the scene that greatly helps with making the scene visible for the lens. It delivers color images during the day and automatically switches to the monochrome feature as the scene darkens.

IK10 Technology

This product has been inculcated with the IK10 vandal resistance technology which is the topmost mechanical protection in the surveillance industry. This technology enables your camera in developing a strong and robust appearance that can't be defeated by water, dust or even severe shocks as the powerful housing of this camera deters any damage from occurring.

About CP PLUS

The brand that is on its way to lead the world when it comes to the security and surveillance industry, CP PLUS, keeps bombarding the market with the most reliable range of products that have been designed carefully and methodically to automate the whole surveillance and security process, no matter how big your premises are.

It was the initiative to help the public in the area where they are the most vulnerable and to empower the sense of safety in our hearts that had conceptualized CP PLUS. And embarking on its mission to make the world a safer and more secure place has taken the brand's journey to unprecedented levels even when compared to international competitors.



CP-UNC-VE21ZL4C-VMDS-Q

2MP Network IR Vandal Dome Camera - 40Mtr.

Feature	Specification
Image Sensor	1/2.8" 2MP PS CMOS Image Sensor (0.9071 Centimeter)
Minimum Illumination	0.006 Lux@F1.6(Color,30IRE), 0.0006 Lux@F1.6(B/W,30IRE) 0 lux (IR on)
Effective Pixels	1920 (H) × 1080 (V)
Shutter Speed	Auto/Manual 1/3 s–1/100,000 s
Angle Adjustment	Pan: 0°–355°, Tilt: 0°–65°, Rotation: 0°–355°
RAM	512 MB
ROM	128 MB
White Balance	Auto, natural, street lamp, outdoor, manual, regional custom
Lens	2.7mm~13.5mm
Gain Control(AGC)	Auto
Lens Type	Motorized
Iris Type	Fixed
Max. Aperture	F1.6
Lens Mount	M14
Close Focus Distance	0.8 Mtr.
DORI Distance	W: 44.1 Mtr. (Detect), 17.7 Mtr. (Observe), 8.8 Mtr. (Recognize), 4.4 Mtr.(Identify) T: 144.8 Mtr. (Detect), 57.9Mtr. (Observe), 29.0Mtr. (Recognize), 14.5 Mtr. (Identify)
Back Light Compensation	BLC / HLC / WDR(120dB)
Angle of View	H: 109°–30°, V: 56°–17°, D: 131°–35°
stream Capability	Quad Stream
S/N Ratio	>56 dB
Video Format	PAL/NTSC
Video Compression	Instastream, H.265, H.264+, H.264, H.264H, H.264B, MJPEG (Only supported by the sub stream)
Resolution	2MP(1920 × 1080), 1.3MP(1280 × 960), 1MP(1280 × 720), D1(704 × 576/ 704 × 480), VGA(640 × 480), CIF(352 × 288/ 352 × 240)

Feature	Specification
Bit Rate Control	CBR/VBR
Bit Rate	H.264: 3 kbps–6144 kbps, H.265: 3 kbps–6144 kbps
Noise Reduction	3D DNR
Image Stabilization	Electronic Image Stabilization (EIS)
Motion detection	OFF/ON (4 Areas, Rectangular)
Privacy Mask	4 Area
ROI	Support (4 Areas)
Two-Way Talk	Support
Audio Input	1 Channel (RCA port)
Audio Output	1 Channel (RCA port)
Audio Compression	PCM, G.711a, G.711Mu, G.726, MPEG2-Layer2, G.722.1
Audio	Built-in Mic
Alarm IN	1 channels in: 5mA 3V–5V DC
Alarm Out	1 channel out: 300mA 12V DC
OSD	Camera title, Date & Time
Protocol	SFTP, IPv6, IPv4, DNS, RTCP, NTP, RTP, HTTP, HTTPS, SNMP V1/V2/V3, TCP/IP, PPPoE, UPnP, NFS, UDP, ICMP, SSL, DHCP, SMTP, RTSPS, ONVIF (Profile S, Profile G, Profile T), unicast, Multicast
IVS (Optional)	Tripwire, Intrusion, Object Abandon/ Missing, IMD (Intelligent motion detection), Face Detection
SDK and API	Support
Ethernet	RJ-45 (10/100Base-T)
Day/Night	Auto(ICR)/Color/B/W
Alarm Event	Motion/tampering detection, audio detection, network disconnection detection, IP conflict detection, memory card state detection, memory space detection
Cyber Security	AES 256-bit Encryption, Configuration encryption, trusted execution, Digest, security logs, WSSE, account lockout, syslog, video encryption, IP/MAC filtering, HTTPS, trusted upgrade, trusted boot.
User/Host	20 (Total bandwidth: 80 Mbps)
Browser	Microsoft Edge and Chrome
Mirror Function	Support

Feature	Specification
Storage	SFTP, Micro SD card (support max. 512 GB), NAS
Frame Rate	Main stream: 2MP/1.3MP/1MP/D1 @(1-25/30fps) Sub stream 1: D1/VGA/CIF@(1-25/30fps) Sub stream 2: 2MP/1.3MP/1MP/D1@(1-25/30fps) Sub stream 3: D1/VGA/CIF@(1-25/30fps)
IR Distance	40 Mtr. (IR)
IR Number	3 (IR LED)
Image Rotation	0°/90°/180°/270° (Support 90°/270° with 1080p resolution and lower)
Defog	Support
Certificates	MTBF Certificate from STQC, ISO 9001: 2015, ISO 20000-1 : 2018, CE, FCC and RoHS, BIS, STQC approved compliance report
Weatherproof Standard	IP67 & IK10
Operating Temperature	-30 °C to +60 °C (-22 °F to +140 °F)
Operating Humidity	≤95% RH, non-condensing
Storage Temperature	-40 °C to +60 °C (-40 °F to +140 °F)
Storage Humidity	10%–95% RH, non-condensing
Power Source	12 VDC/24 VAC/PoE (802.3af)
Power Consumption	Basic: 1.6 W (12 VDC), 1.9 W (24 VAC), 3.1 W (PoE) Max. (H.265 + WDR + Intelligence on + IR on: 7.9 W (12 VDC), 9.5 W (24 VAC), 9.9W (PoE)
Casing	Metal
Dimension	159.1 mm × 118.1 mm
Weight	0.91 kg

Published Date –28-04-2025

Dimensions (mm/inch)

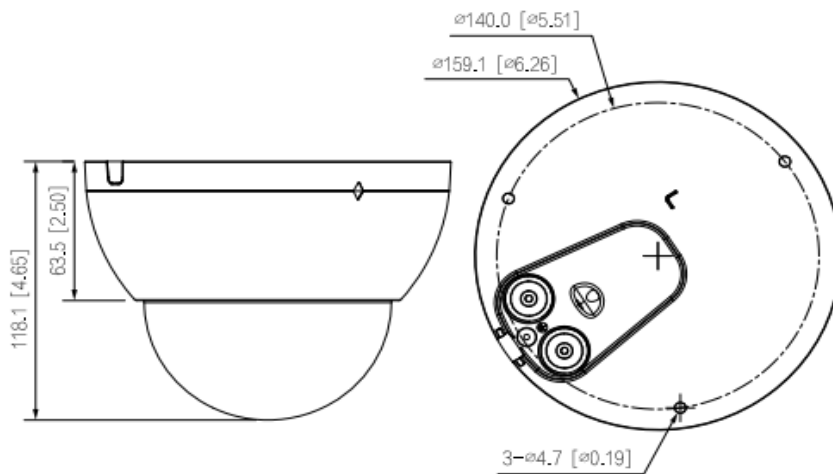

Company Name:

CP PLUS (Aditya Infotech Ltd.)

F-28 Okhla Industrial Area, Phase 1,

New Delhi 110020, INDIA

Contact Mail ID :- customercare@cpplusworld.com